

Nylon Bracket SHF-85-138
Spring SHF-85-107
Rivet SHF-85-160
Cross Head Screw SHF-85-131
Heald Frame Assembly Screw SHF-85-152

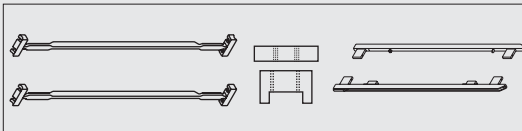

Center Support SHF-85-172
Center Support SHF-75-174
Moving Piece SHF-85-170
Moving Piece SHF-85-171
Steel Side Support SHF-85-005
Steel Side Support SHF-85-006

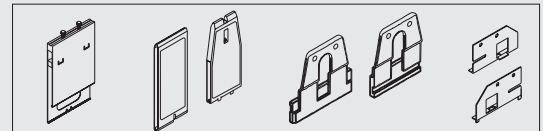

Protecting Cap SHF-85-290
Separators - TOP Profile SHF-85-162
Separators - BOTTOM Profile SHF-85-161
Steel Heald Rod Holder for Bottom Profile SHF-85-221
Fixed Steel Heald Rod Holder with Spring for Top Profile SHF-85-222
End Hooks SHF-85-124
End Hooks SHF-85-105

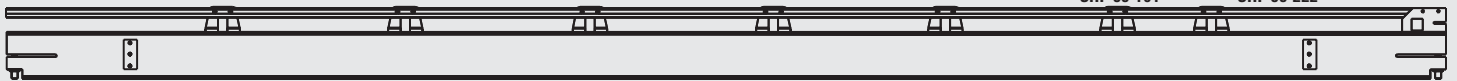

'J' type SHF-85-2503

Bottom Profile with 'C'/J' type Heald Rod and Hooks

'C' type SHF-85-2504

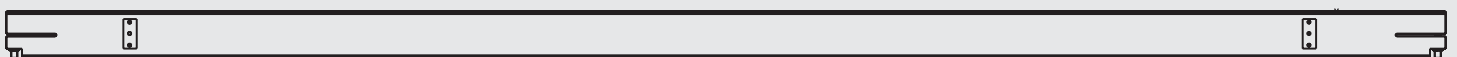

Bottom Profile without Heald Rod and Hooks SHF-85-2500



Heald Rod 'J' type SHF-85-503



Heald Rod 'C' type SHF-85-504

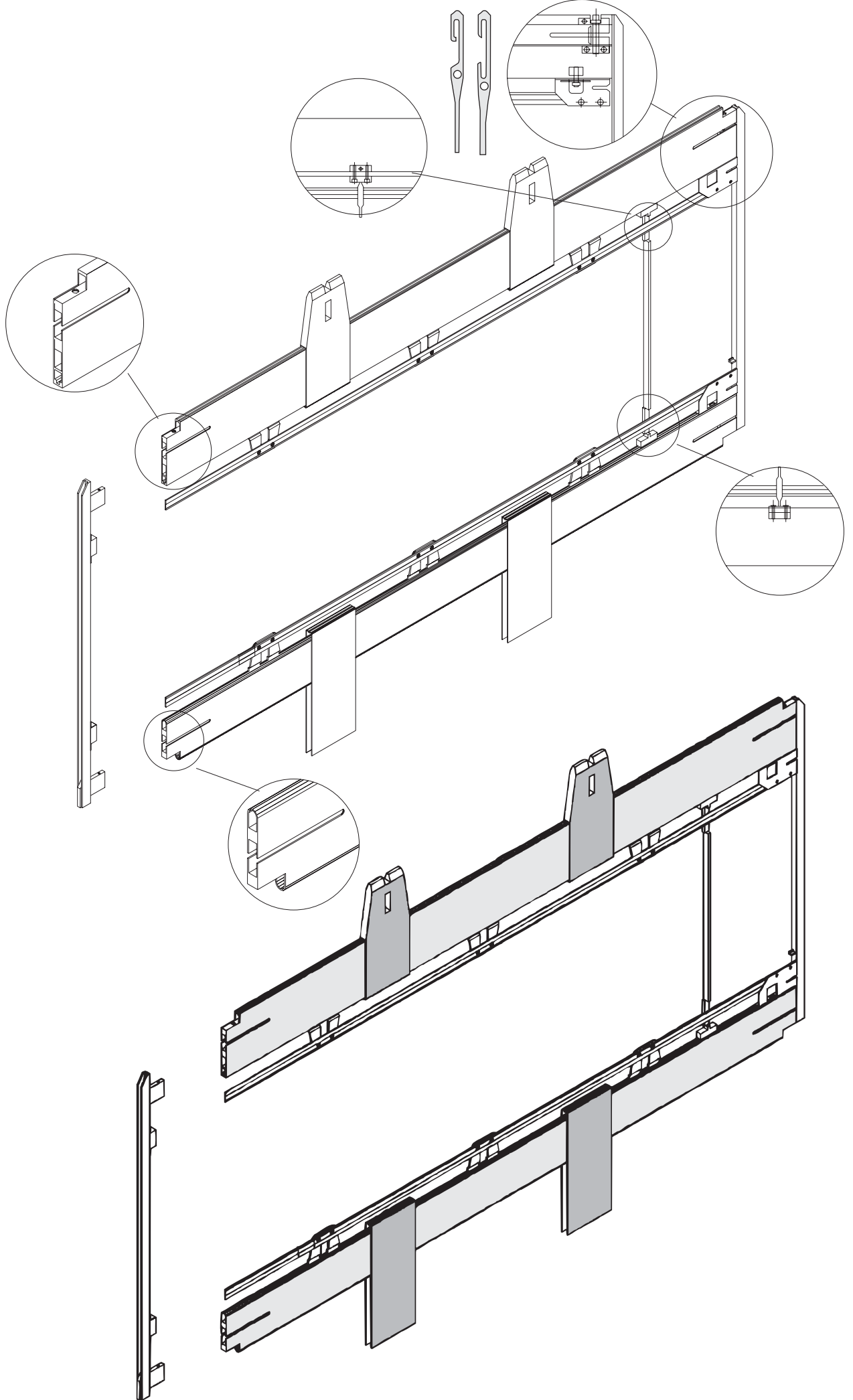

Bottom Profile : Mild Steel 68mm x 9.5mm / 75mm x 9.5mm Profiles with STEEL Heald Rod Holders. 2-3 Heald Frame Holding Piece Harden & Tempered Spot Welded at required distance.

Top Profile : Aluminium 90mm x 9.5mm Triple Hollow having fixed type STEEL Heald Rod Holders, Hollow Portion of Profile can be filled with foam for noise reduction, if ordered.

Heald Rod : Harden & Tempered duly Nichrome Plated - 16mm x 2mm Grooved for 'J' type Healds & 22mm x 1.6mm for 'C' type Healds

Side Support : Interchangeable Steel 'C' Section of 15mm x 10mm Grooved, made from Single Solid Section. One Side having Steel Heald Rod Holding Clamp with PU insert for Holding Heald Rod, other side having 'L' type Piece for resting Heald Rod.

Center Support : Stainless Steel forged fixed type / Movable to hold rigidly both Profiles at required center to protect elongation of the Frame.

Heald Rod Distance : 327mm / 328mm for 331 mm Healds.

Separators : Detachable / Fixed type 180mm X 80mm X 12mm for Heald Frame Protection.

Steel Protecting Cap : 2 PCS. for each set of 10-18 PCS. Heald Frame can be provided, if ordered.

Warranty: We can offer ONE-YEAR warranty for Free Repairs against manufacturing defects for all varieties of Heald Frames.

We undertake repairing & servicing of Any Other Make Heald Frame providing interchangeable New Bottom Profiles With OR Without Heald Rod and other required Components & Accessories.

Harnesses, Harness Connector & Loop Connector for all sizes of Sulzer Weaving Machine can be offered

PART NO. OF ACCESSORIES

Part No.	Descriptions
SHF-85-2503	Bottom Profile 'J' type Heald Rod with steel Heald Rod Holders
SHF-85-2504	Bottom Profile 'C' type Heald Rod with steel Heald Rod Holders
SHF-85-2500	Bottom Profile without Heald Rod and Heald Rod Holders
SHF-85-1503	Top Profile having 'J' type Heald Rod with steel Heald Rod Holders
SHF-85-1504	Top Profile having 'C' type Heald Rod with steel Heald Rod Holders
SHF-85-1500	Top Profile without Heald Rod and Heald Rod Holders
SHF-85-503	Heald Rod 'J' type - 16mm x 2mm Grooved duly Nichrome plated
SHF-85-504	Heald Rod 'C' type - 22mm x 1.6mm duly Nichrome plated
SHF-85-221	Steel Heald Rod Holder for Bottom Profile
SHF-85-222	Fixed Steel Heald Rod Holder with Spring for Top Profile
SHF-85-124	Steel end piece for Top Profile
SHF-85-105	Steel end piece for Bottom Profile
SHF-85-107	Spring for End Piece
SHF-85-127	Hex Screw for End Piece
SHF-85-160	Rivet for Heald Rod - Turned Unleaded
SHF-85-152	Heald Frame Assembly Screw - Square Headed - High Carbon H & T
SHF-85-162	Separators - Top Profile for 90mm x 9mm Aluminum Profile
SHF-85-161	Separators - bottom Profile for 68mm x 9.5mm Steel Section
SHF-85-161	Separators - bottom Profile for 75mm x 9.5mm Steel Section
SHF-85-161	Separators - bottom Profile for 63mm x 9.5mm Steel Section
SHF-85-170	Moving Piece for Center Support MS Profile
SHF-85-172	Center Support for MS to ALU. H.Frame for 130", 143" & 153"
SHF-75-174	Center Support for MS to MS H.Frame for 130", 143" & 153"
SHF-85-159	Center Support for MS to ALU. CONTI-85 H. Frame 85" (220CMS.)
SHF-85-173	Center Support for MS to MS CONTI-85 H. Frame 85" (220CMS.)
SHF-85-131	Cross Head Screw for Center Support
SHF-85-005	Steel Side Support for MS to MS. Profile with Lock Piece
SHF-85-006	Steel Side Support for MS to MS. Profile with 'C' Clamp
SHF-85-138	Nylon Bracket for Steel Side Support
SHF-85-290	Protecting Cap

Please indicate size & type of the Weaving Machine while ordering Top / Bottom Profile OR Heald Rod.

Width Machine		Length Heald Frame	Center Support	Separator Top Profile	Separator Bottom Profile
Inch	Cms.	in mm	Per Frame		
85"	220	2258	1Pc.	2-3 PCS.	1Pc.
110"	280	2890	1-2 PCS	3-4 PCS.	2 PCS.
130"	330	3400	1-2 PCS	4-5 PCS	2 PCS.
153"	390	3988	2-3 PCS.	4-5 PCS.	3 PCS.
213"	540	5508	3-4 PCS.	8-9 PCS.	5 PCS
220"	550	5650	3-4 PCS.	8-9 PCS.	5 PCS.

Please indicate type & quantity of center supports & separators required per frame.

Our Other Products: All Metal REED, Riderless Healds, Drop Pins, Electrical Contact Bar, and Leno Doup Healds.

Odd is Even for Continental's

Need is the mother of all inventions, we in Continental's do not see anything impossible. We create the products for the knish market also & we can also provide the tailor-made solutions for



Continental Engineering Industries (P) Ltd.

"PANNA" 46/B/2, Swastik Society, Navrangpura, Ahmedabad - 380 009.

Ph. +91-79-26441498, 26441580, 26567547. FAX :+91-79-26440947

E-mail : conti@icenet.co.in; conti@weavingaccessories.com

www.WeavingAccessories.com

140, Great Western Bldg., Nagindas Mst. Road Extn, Mumbai - 400023.

Ph.:+91-22-22844373

Plot No. 503/504, G.I.D.C. Engg. Zone, Sector-28, Gandhinagar - 382028.

Ph. :+91-79-23211399, 23211815